

● Monocoque Caliper Installation Tips

Thank you for choosing Spoon products.
Here we will show you some installation tips.

○ Fixing the Back Plate

Use an air saw or such to cut off the "A" section which interferes with the back plate.

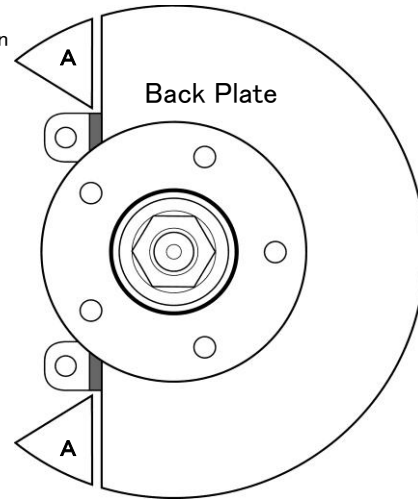

○ Placement of the washer (included)

Photo①: Please use the included washer for the attachment of the caliper and brackets.
Before finally tightening to the specified torque, turn the rotor and check to see if there is enough clearance.

Photo②: Please use the included bolt for the attachment of the bracket to the knuckle.

Connecting the caliper and bracket

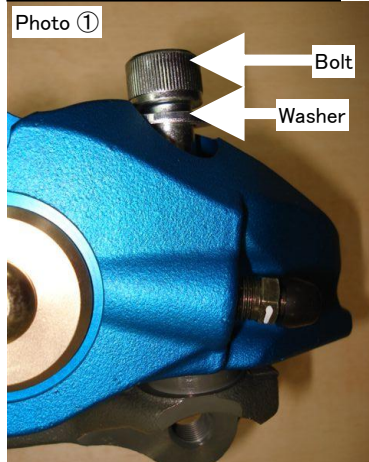

Tightening torque: $53.9\text{N}\cdot\text{m}$ (5.5kgf)

Connecting bracket to vehicle

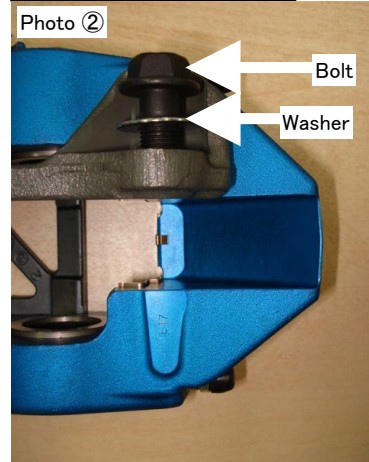

Tightening torque: $108\text{N}\cdot\text{m}$ (11kgf)

● What to care for after installing you new calipers

○ How To Fit Brakepads



First loosen bolt **A** and remove the **B** plate to fit the brake pads.

After fitting brake pads reverse the process by placing back the **B** plate and finally tightening bolt **A**.

Specified bolt tightening torque:
『**A**』bolt: $11.7\text{N}\cdot\text{m}$ (1.2kgf)

○ Releasing Air

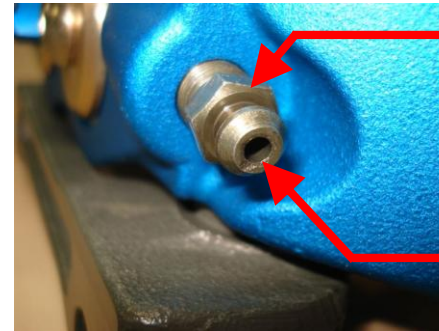

Attention: Do not over tighten the bleeder!

At cool conditions the bleeder tightening torque must be $6.9\text{N}\cdot\text{m}$ (0.7kgf).

Excessive tightening can result in warping the bleeder and/or damage(overshoot) the screw. Please take extra care when doing this.

The fluid inside the bleeder bolt will become hot during driving, so clean well using brake cleaners to remove any grease from inside the bleeder. There is no problem if a small amount of fluid smudges from inside the bleeder.