

Spoon Twin Block Calipers Installation Tips

Thanks for choosing Spoon products.
Here, we will show you some installation tips.

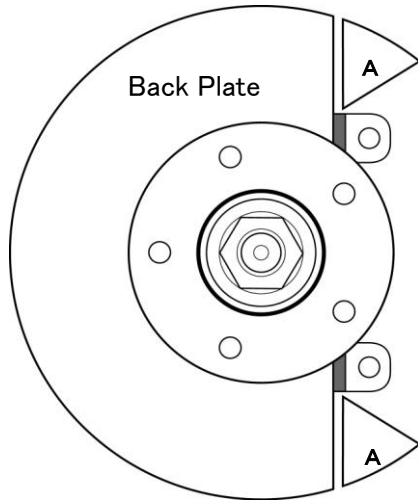

○Fixing the back plate

Use an air saw or such to cut off the "A" section which interferes with the back plate.

○Placement of the washer (included)

Depending on the model, the placement of the washer will vary. Find your model from the reference below for proper fitting.

Use the included special bolt to install. Do NOT use the original stock bolts from your car to install the Spoon calipers.

Tightening torque is 108N·m(11gf)

○EG2/6/9, EK4/9, DC2/DB8 TYPE-R '96spec

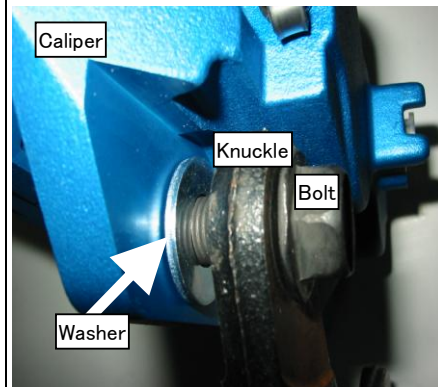

○DC2/DB8 TYPE-R '98spec

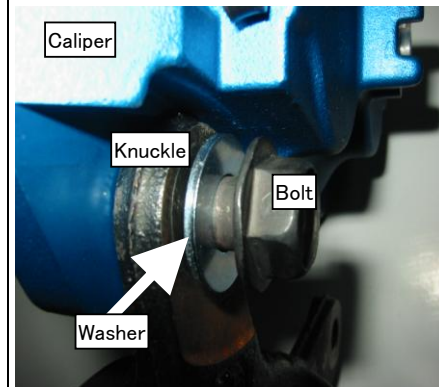

What to care for after installing you new calipers

○Instructions on how to fit brake pads

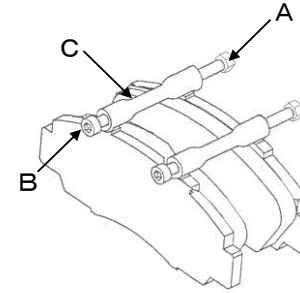

First loosen nut "A".
Next loosen bolt "B".
Remove the "C" collar.

After fitting the brake pads, place the collar back on, tighten "B" bolt and "A" nut.

Specified Torque:

『A』Nut:11.7N·m(1.2kgf)

『B』Bolt:15.4N·m(1.6kgf)

○Releasing Air

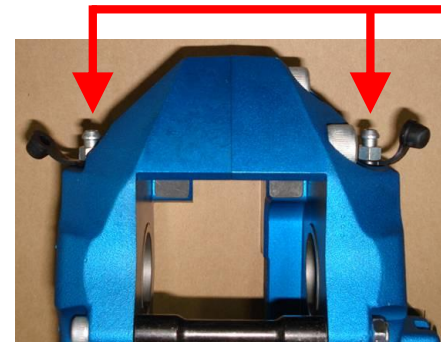

Attention: Do not over tighten the bleeder!

At cool conditions the bleeder torque must be 5.8N·m(0.6kgf).

The fluid inside the bleeder bolt will become hot during driving, so clean well using brake cleaners to remove any grease from inside the bleeder. There is no problem if a small amount of fluid smudges from inside the bleeder.

Excessive tightening can result in warping the bleeder and/or damage(overshoot) the screw.

Please take extra care when doing this.